

THE



CARBURETTER

BASIC PRINCIPLES

MANUFACTURED

by

THE S.U. CARBURETTER COMPANY LIMITED

Proprietors: MORRIS MOTORS LIMITED

WOOD LANE • ERDINGTON • BIRMINGHAM 24

TELEPHONE: ERDINGTON 7371 (9 lines)

TELEGRAMS: CARBURFLEX, BIRMINGHAM



GENERAL

The ideal carburettor is an instrument which when correctly tuned will supply its engine with the optimum mixture for maximum power throughout the full throttle range and for minimum consumption under all part-throttle conditions.

The fixed choke

When air is passed through a choke of fixed size its velocity and the depression over the fuel jet will vary with the demands of the engine. This varying depression makes it necessary to employ com-

pensating devices to produce the correct fuel flow and also imposes a compromise on the choice of choke size in that, too small an orifice will produce a restriction at the top end of the output range, whilst a large orifice will cause poor metering and indifferent carburation at the lower end of the range.

The variable choke

The principle of the variable choke carburettor is to employ a means whereby the effective choke orifice will expand as the demand increases, and contract when the demand diminishes. Such a variation in choke area will achieve a constant air velocity and depression over the jet.

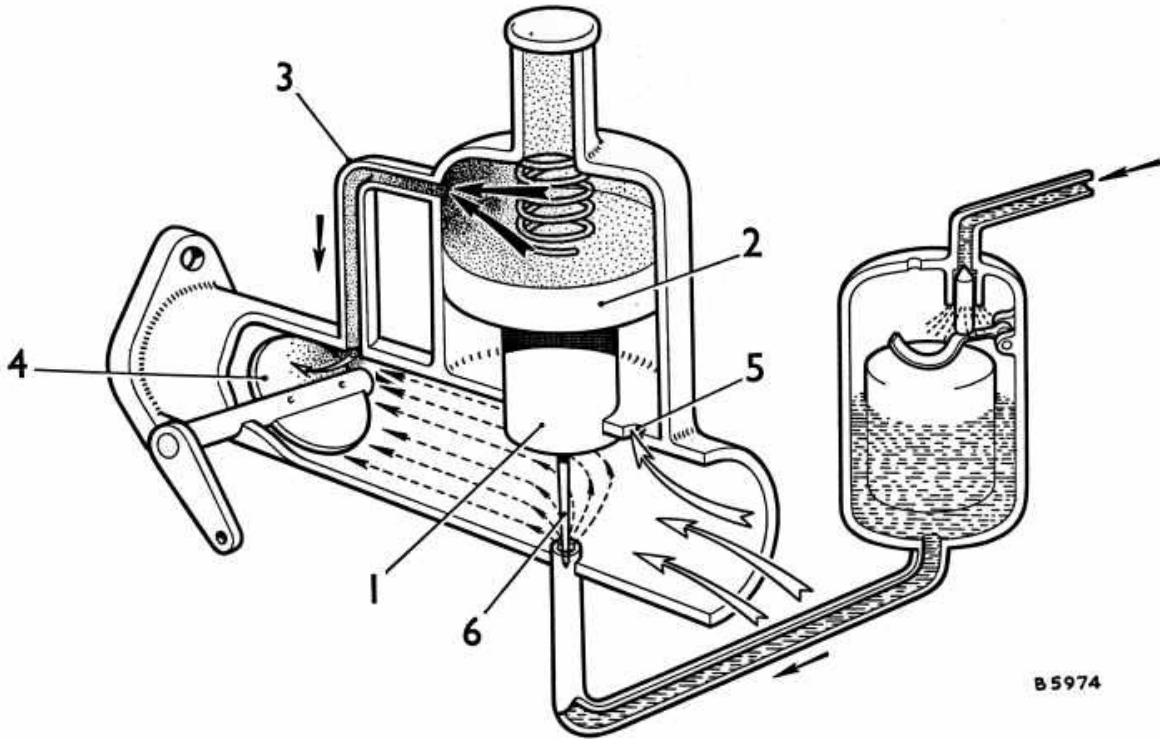

Fig. 1. The S.U. carburettor—basic construction (theoretical)

THE S.U. CARBURETTOR—BASIC CONSTRUCTION (Theoretical)

Choke

A variable choke orifice is obtained in the S.U. carburettor by the vertical movement of a close-fitting piston (1) (Fig. 1) positioned above the fuel jet in the centre of the body casting. A suction disc (2) is integral with the piston and works in a concentric chamber bolted to the top of the body casting.

Drillings in the under face or side of the piston, shown for simplicity as an external duct (3), communicate any depression existing in the space between the piston (1) and the throttle disc (4), to the chamber above the suction disc (2). The under side of the suction disc is vented to atmosphere or to the air cleaner by transfer holes located in the inlet flange shown simply by the drilling (5).

Jet

As the choke orifice is varied over wide limits by the movement

of the piston throughout the speed range, the fuel jet orifice must also be varied. This is achieved by means of a tapered needle (6) attached to the piston and projecting into the jet. Correct discharge areas are obtained by the accurate dimensioning of this needle.

Operation

Opening the throttle disc (4) allows the manifold depression to be communicated to the body of the carburettor and also to the chamber above the suction disc. The piston will rise, allowing a mixture of air and fuel to pass underneath it to relieve the depression. The piston will continue to rise until the depression has reached a value which is just sufficient to balance the weight of the piston, together with the load exerted by the piston spring.

It will be appreciated that approximately the same depression can be obtained whatever the demand and that the piston height will be governed by the mass of mixture flowing beneath it. This depression is arranged to be of sufficient value to ensure that good atomization is obtained, but small enough to ensure adequate engine filling at high speeds.

ADDITIONS TO THE BASIC DESIGN (Theoretical)

Cold start mixture control

Operation of the cold start mixture control (7) (Fig. 2) will lower the jet down the needle (maximum movement $\frac{1}{8}$ in. (11 mm.)) exposing a large annulus and so providing the rich mixtures required for the cold start and initial 'warm up' period.

Jet lever/throttle interconnection

On most S.U. carburetters there is a connection (8) between the jet lever (9) and the throttle disc control (10). The connection is such that on operation of the cold start/mixture control, the first few degrees of movement of the jet lever (9) open the throttle disc without moving the jet. Successive movement of the jet lever lowers the jet and opens the throttle disc by a further amount.

Piston damper assembly

A one-way valve is incorporated in the damper plunger (11) and this is fitted in an oil-filled reservoir in the hollow piston rod (12). The piston damper assembly will restrict the rate by which the piston lifts, but will allow it to fall freely on throttle closure. The primary purpose of the piston damper is to provide the enrichment necessary for a satisfactory 'pick-up' during rapid opening of the throttle.

This enrichment is achieved by the damper retarding the speed of piston lift, thereby creating an additional depression over the jet which increases the amount of fuel discharged. When the engine is cold, the viscosity of the oil in the damper is high and the enrichment obtained is therefore greater than when the oil is warm.

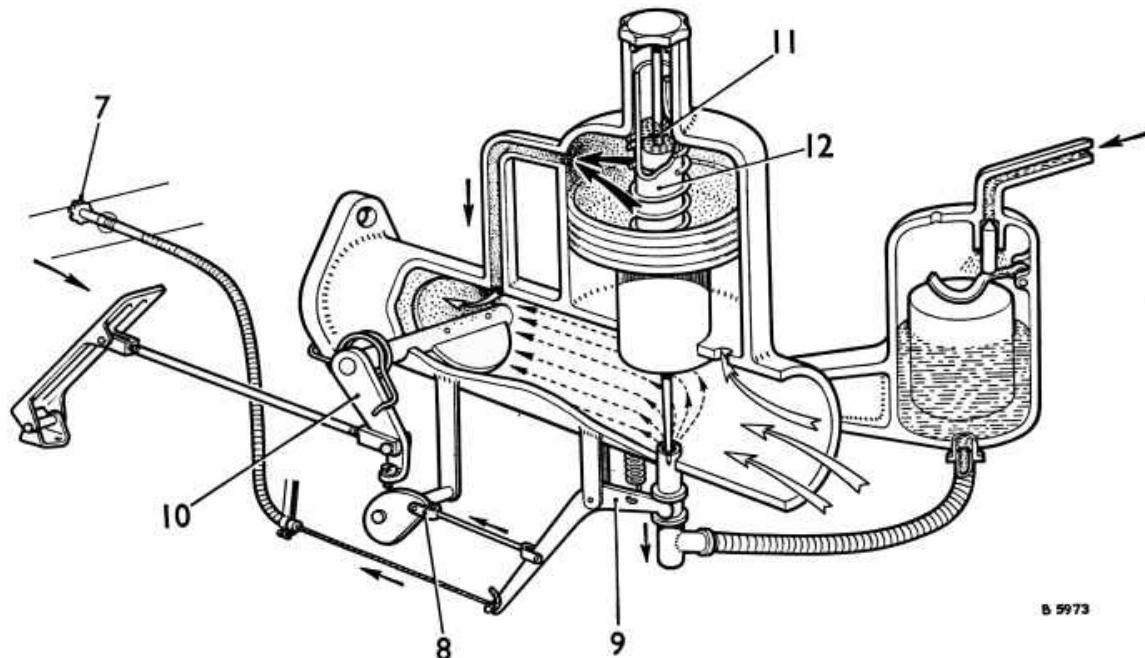

Fig. 2. Additions to the basic design (theoretical)

THE S.U. CARBURETTER (Practical)

General

Fig. 3 shows a sectional view of an H-type carburettor with the choke at 30° to horizontal, and illustrates the piston drillings (13) which communicate the choke depression to the chamber above the suction disc in practice.

The clevis pin (20) provides the fulcrum for lowering the jet, but as the drilling in the jet lever is large the initial movement operates the fast idle cam (22) and thus the throttle disc, without moving the

jet. The float-chamber is provided with an air vent (21) which is sometimes arranged to operate through an overflow pipe.

Adjustments

The jet adjusting nut (14) positions the jet (15) in relation to the needle (16) and provides for adjustment of mixture strength.

The throttle adjusting screw (17) provides a means of setting engine idling r.p.m.

The fast idle adjusting screw (18) sets the amount of throttle disc opening when the cold start/mixture control is used.

